

# 500VA Toroidal Power Transformer(Dual Input :2\*115V, Output:25V×2)

## 1、 Theory Picture:

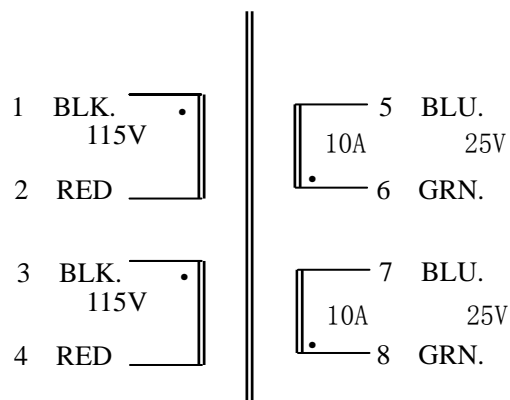

## 2、 The Transformer Practicality Picture:



Product	Capacity (VA)	Dimension		Weight (kg)	Install Bore (mm)	Screw (mm)
		D(mm)	H(mm)			
Toroidal Transformer	500	150	67	4.7	φ 8.5	M8
Primary Rated Input			115V/50HZ×2			
Electric Resistance of Primary Directory Current			2.9 Ω			
Max No-loading Current			46 mA			
Insulation Capability			Primary-Secondary: 500VDC≥100M Ω			
Dielectric Strength Test			Primary-Secondary: 4000V 5mA 60s			
Temperature Rise			≤65℃			
Secondary Rated Output						
	No-loading Voltage(V±5%)	Loading Voltage (V±5%)		Rated Loading Current (A)		
S1: 5~6、7~8	25V×2	24×2		10		
Derivation Line Specification						
	Color		Specification		Length (mm)	Terminals
Line: 1~2 3~4	BLK.-RED	BLK.-RED	UL-1672	18#	310	5mmTin Imbrued
Line: 5~6 7~8	BLU.-GRN.	BLU.-GRN.	UL-1015	12#	310	5mmTin Imbrued

Toroidal Power Transformer Install Sketch Map:

Toroidal Power Transformer Dimension Picture:

