

# 50VA Toroidal Power Transformer(Dual Input :2\*115V, Output:25V×2)

1、 Theory Picture:

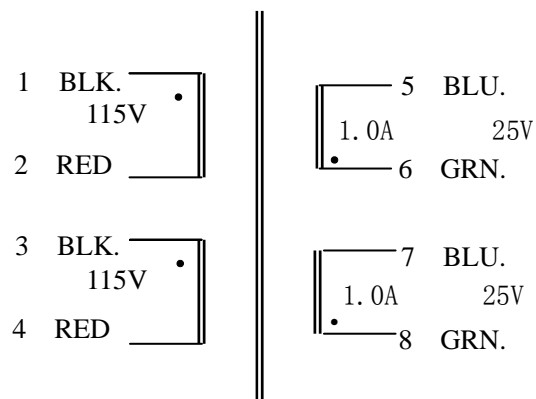

2、 The Transformer Practicality Picture:



Product	Capacity (VA)	Dimension		Weight (kg)	Install Bore (mm)	Screw (mm)
		D(mm)	H(mm)			
Toroidal Transformer	50	88	34	0.8	φ 8.5	M8
Primary Rated Input			115V/50HZ×2			
Electric Resistance of Primary Directory Current			47 Ω			
Max No-loading Current			14 mA			
Insulation Capability			Primary-Secondary: 500VDC ≥ 100M Ω			
Dielectric Strength Test			Primary-Secondary: 4000V 5mA 60s			
Temperature Rise			≤ 65°C			
Secondary Rated Output						
	No-loading Voltage(V ± 5%)	Loading Voltage (V ± 5%)	Rated Loading Current (A)			
S1: 5 ~ 6 、 7 ~ 8	25V×2	22V×2	1.0			
Derivation Line Specification						
	Color		Specification		Length (mm)	Terminals
Line: 1 ~ 2 3 ~ 4	BLK.-RED	BLK.-RED	UL-1672	18#	310	5mmTin Imbrued
Line: 5 ~ 6 7 ~ 8	BLU.-GRN.	BLU.-GRN.	UL-1015	22#	310	5mmTin Imbrued

Toroidal Power Transformer Install Sketch Map:

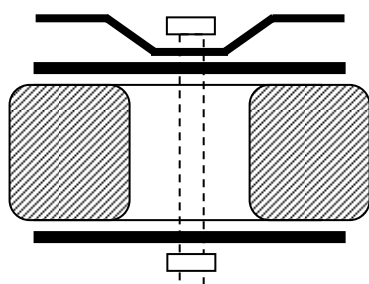

Toroidal Power Transformer Dimension Picture:

