

50VA Toroidal Power Transformer(Dual Input :2*115V, Output:15V×2)

1、Theory Picture:

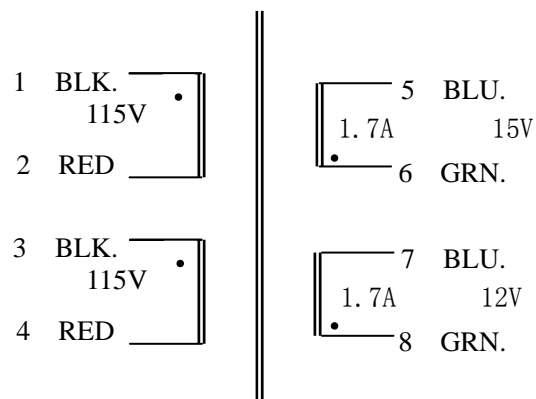

2、The Transformer Practicality Picture:



Product	Capacity (VA)	Dimension		Weight (kg)	Install Bore (mm)	Screw (mm)
		D(mm)	H(mm)			
Toroidal Transformer	50	89	34	0.8	φ 8.5	M8
Primary Rated Input			115V/50HZ×2			
Electric Resistance of Primary Directory Current			49.3 Ω			
Max No-loading Current			9 mA			
Insulation Capability			Primary-Secondary: 500VDC≥100M Ω			
Dielectric Strength Test			Primary-Secondary: 4000V 5mA 60s			
Temperature Rise			≤65℃			
Secondary Rated Output						
	No-loading Voltage(V±5%)	Loading Voltage (V±5%)		Rated Loading Current (A)		
S1: 5~6、7~8	15V×2	13.5 V×2		1.7		
Derivation Line Specification						
	Color		Specification		Length	Terminals
Line: 1~2 3~4	BLK.-RED	BLK.-RED	UL-1672	18#	310	5mmTin Imbrued
Line: 5~6 7~8	BLU.-GRN.	BLU.-GRN.	UL-1015	20#	310	5mmTin Imbrued

Toroidal Power Transformer Install Sketch Map:

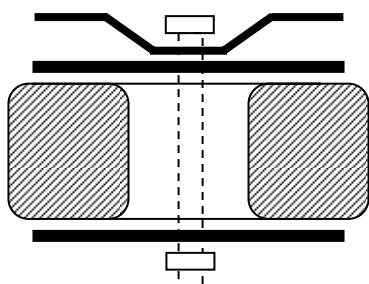

Toroidal Power Transformer Dimension Picture:

