

150VA Toroidal Power Transformer(Dual Input :2*115V, Output:250V*2; 6.3V; 12.6V)

1、Theory Picture:

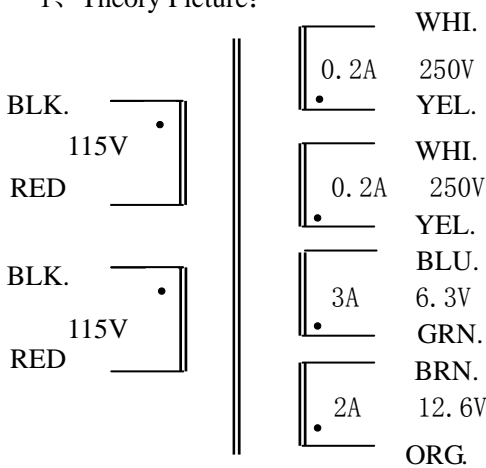

2、The Transformer Practicality Picture:

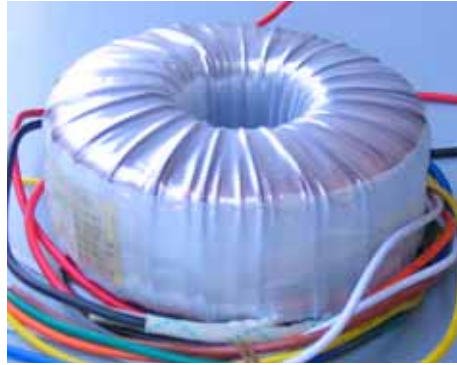

Product	Capacity (VA)	Dimension		Weight (kg)	Install Bore (mm)	Screw (mm)
		D(mm)	H(mm)			
Toroidal Transformer	150	112	51	1.86	φ 8.5	M8
Primary Rated Input			115V/50HZ×2			
Electric Resistance of Primary Directory Current			14 Ω			
Max No-loading Current			18 mA			
Insulation Capability			Primary-Secondary: 500VDC≥100M Ω			
Dielectric Strength Test			Primary-Secondary: 4000V 5mA 60s			
Temperature Rise			≤65℃			
Secondary Rated Output						
	No-loading Voltage (V±5%)		Loading Voltage (V±5%)		Rated Loading Current (A)	
Output	250V×2	6.3V 12.6V	230V 5.8V 11.6V	0.2A	3A	2A
Derivation Line Specification						
	Color		Specification		Length (mm)	Terminals
Input	BLK.-RED	BLK.-RED	UL-1672	18#	310	5mmTin Imbrued
Output	WHI.-YEL. BLU.-GRN.	WHI.-YEL. BRN.-ORN.	UL-1015	22#18#20#	310	5mmTin Imbrued

Toroidal Power Transformer Install Sketch Map:

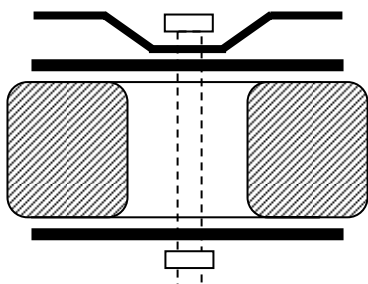

Toroidal Power Transformer Dimension Picture:

