

# 25VA Toroidal Power Transformer(Dual Input :2\*115V, Output:20V×2)

## 1、 Theory Picture:

## 2、 The Transformer Practicality Picture:

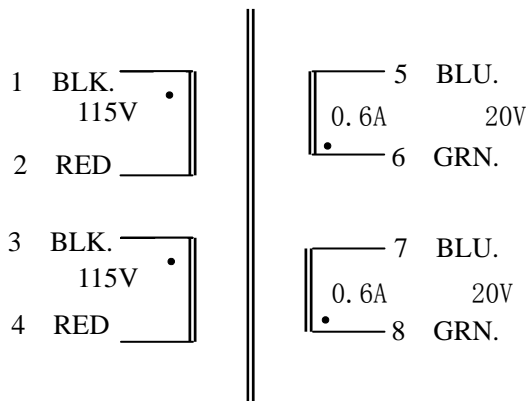

Product	Capacity (VA)	Dimension		Weight (kg)	Install Bore (mm)	Screw (mm)
		D(mm)	H(mm)			
Toroidal Transformer	25	78	34	0.523	φ 6.5	M6
Primary Rated Input			115V/50HZ×2			
Electric Resistance of Primary Directory Current			119 Ω			
Max No-loading Current			6 mA			
Insulation Capability			Primary-Secondary: 500VDC≥100M Ω			
Dielectric Strength Test			Primary-Secondary: 4000V 5mA 60s			
Temperature Rise			≤65°C			
Secondary Rated Output						
	No-loading Voltage (V±5%)	Loading Voltage (V±5%)		Rated Loading Current(A)		
S1: 5~6、7~8	20V×2	17.8 V×2		0.6		
Derivation Line Specification						
	Color		Specification		Length (mm)	Terminals
Line: 1~2 3~4	BLK.-RED	BLK.-RED	UL-1672 22#		310	5mmTin
Line: 5~6 7~8	BLU.-GRN.	BLU.-GRN.	UL-1015 22#		310	5mmTin

Toroidal Power Transformer Install Sketch Map:

Toroidal Power Transformer Dimension Picture:

